

Digital View

ANALOG INTERFACE CONTROLLER FOR 1024 x 768 RESOLUTION TFT LCD

Model: AC-1024

(Part number: 4106891-XX)

INSTRUCTIONS

CONTENTS

Page:	2. Introduction, How to Proceed, Usage Note, Disclaimer
	3. Quick Guide
	5. System design – Diagram of a suggested system
	6. Assembly notes – Important information about system elements
	9. Connection & Operation – How to use the controller
	13. Connectors, pinouts & jumpers – Essential connection information
	19. Controller dimensions
	20. Application notes
	22. Troubleshooting
	23. Specifications
	24. Warranty, Caution & Limitation of Liability, Trademarks
	25. Contact details

It is essential that these instructions are read and understood before connecting or powering up this controller.

Introduction

Designed for LCD monitor and other flat panel display applications the AC-1024 controller provides an auto-input synchronization and easy to use interface controller for:

- TFT (active matrix) LCD s of 1024 x 768 resolution;
- Computer video signals of VGA, SVGA & XGA standard.
- Video signals of PAL & NTSC standard (optional add-on board required)
- Volume control of audio (optional add-on board required)

HOW TO PROCEED

- Ensure you have all parts & that they are correct, refer to:
 - Connection diagram (separate document for each panel)
 - Connector reference (in following section)
 - Assembly notes
- Check controller switch & jumper settings (errors may damage the panel)
- Prepare the PC
- Connect the parts
- Understand the operation & functions

IMPORTANT USAGE NOTE

This equipment is for use by developers and integrators, the manufacturer accepts no liability for damage or injury caused by the use of this product. It is the responsibility of the developer, integrators or other user of this product to:

- Ensure that all necessary and appropriate safety measures are taken.
- Obtain suitable regulatory approvals as may be required.
- **Check power settings to all component parts before connection.**

DISCLAIMER

There is no implied or expressed warranty regarding this material.

Quick Guide

Controller setup table for Normal Version: 4106891-06/07

Panel	Settings			Accessories		
	Panel power JP6, JP7, JP12	Panel BIOS SW1	Inverter (note 1) JP2, JP3	Panel Connection	Inverter	Control
BATRON						
EDTCF02QAF 15", 1024x768, 18-bit 5V, 4X CCFT	JP6: 1-2 closed JP7: open JP12: open	#1: on #2: off #3: off #4: off #5: off #6: off	JP2: TBA JP3: TBA	416210300 420687511 420687451	TBA	410680550 or 410680511
Fujitsu						
FLC38XGC6V 15", 1024x768, 18-bit 5V, 4X CCFT	JP6: 1-2 closed JP7: open JP12: open	#1: on #2: off #3: off #4: off #5: off #6: off	JP2: TBA JP3: TBA	410688632 420689120	TBA	410680560 or 410680521
Hitachi						
TX34D61VC1CAD 13.3", 1024x768, 18-bit 3.3V, 1X CCFT	JP6: 2-3 closed JP7: 1-2 closed JP12: open	#1: off #2: off #3: off #4: off #5: off #6: on	JP2: 1-2 closed JP3: 1-2 closed	410688650 420689160	BDA-003	410680550 or 410680511
TX36D11VCOCAA 14.1", 1024x768, 18-bit 5V, 4X CCFT	JP6: 1-2 closed JP7: open JP12: open	#1: on #2: off #3: off #4: off #5: off #6: off	JP2: TBA JP3: TBA	410688632 420689130	TBA	410680550 or 410680511
Hosiden and Philips						
HLD1506 15.1", 1024x768, 24-bit 5V, 4X CCFT	JP6: 1-2 closed JP7: open JP12: open	#1: on #2: off #3: off #4: off #5: off #6: off	JP2: TBA JP3: TBA	416210200 420687511 420687451 420687520	TBA	410680550 or 410680511
HLD1403 14.5", 1024x768, 18-bit 5V, 4X CCFT	JP6: 1-2 closed JP7: open JP12: open	#1: on #2: off #3: off #4: off #5: off #6: off	JP2: TBA JP3: TBA	410686891 420687451 420687511	TBA	410680550 or 410680511
LG (Lucky Goldstar)						
LP133X1, PanelLink 13.3" 1024x768, 18-bit 3.3V, 1X CCFT	JP6: 1-2 closed JP7: 1-2 closed JP12: open	#1: off #2: off #3: off #4: off #5: off #6: on	JP2: 1-2 closed JP3: 1-2 closed	410688650 420689150	BDA-003	410680550 or 410680511
LP133X4, PanelLink 13.3" 1024x768, 18-bit 3.3V, 1X CCFT	JP6: 2-3 closed JP7: 1-2 closed JP12: open	#1: on #2: off #3: off #4: off #5: off #6: on	JP2: 1-2 closed JP3: 1-2 closed	410688650 420689190	BDA-003	410680550 or 410680511
LP141X1, PanelLink 14.1" 1024x768, 18-bit 3.3V, 1X CCFT	JP6: 1-2 closed JP7: open JP12: open	#1: off #2: off #3: off #4: off #5: off #6: on	JP2: 1-2 closed JP3: 1-2 closed	410688650 420689190	BDA-003	410680550 or 410680511
LM151X1, PanelLink 15.1", 1024x768, 24-bit 5V, 2XCCFT	JP6: 1-2 closed JP7: 1-2 closed JP12: open	#1: off #2: off #3: off #4: off #5: off #6: on	JP2: 2-3 closed JP3: 1-2 closed	410688642 420689141	SI-8390D-02	410680550 or 410680511
LM151X2 15.1" 1024x768, 18-bit 3.3V, 2X CCFT	JP6: 2-3 closed JP7: 1-2 closed JP12: open	#1: off #2: off #3: off #4: off #5: off #6: on	JP2: 2-3 closed JP3: 1-2 closed	426311400	SI-8390D-02	410680550 or 410680511
NEC						
NL10276BC24-04, LVDS 12.1" 1024x768, 18-bit 5V, 1X CCFT	JP6: 1-2 closed JP7: open JP12: open	#1: on #2: off #3: off #4: off #5: off #6: off	JP2: 1-2 closed JP3: 1-2 closed	410688632 420689100	BDA-003	410680550 or 410680511
Samsung						
LT133XM-151 13.3", 1024x768, 18-bit 5V, 2X CCFT	JP6: 1-2 closed JP7: open JP12: open	#1: on #2: off #3: off #4: off #5: off #6: off	JP2: 2-3 closed JP3: 1-2 closed	420687550	Internal inverter	410680550 or 410680511
LT133X1-104, LVDS 13.3", 1024x768, 18-bit 5V, 1X CCFT	JP6: 1-2 closed JP7: open JP12: open	#1: off #2: off #3: off #4: off #5: off #6: off	JP2: 1-2 closed JP3: 1-2 closed	410688632 420689100	BDA-003	410680550 or 410680511
LT150X1-102, LVDS 15", 1024x768, 18-bit 12V, 4X CCFT	JP6: 1-2 closed JP7: open JP12: 1-2 closed	#1: on #2: off #3: off #4: off #5: off #6: off	JP2: TBA JP3: TBA	410688632 420689120	TBA	410680550 or 410680511
LT150X1-151 15", 1024x768, 18-bit 5V, 4X CCFT	JP6: 1-2 closed JP7: open JP12: open	#1: on #2: off #3: off #4: off #5: off #6: off	JP2: 2-3 closed JP3: 1-2 closed	420687550	Internal inverter	410680550 or 410680511

Controller setup table for Normal Version: 4106891-06/07

Panel	Settings			Accessories		
	Panel power JP6, JP7, JP12	Panel BIOS SW1	Inverter (note 1) JP2, JP3	Panel Connection	Inverter	Control
Sharp						
LQ12X12 12.1", 1024x768, 18-bit 5V, 2X CCFT	JP6: 1-2 closed JP7: open JP12: open	#1: off #2: off #3: off #4: off #5: off #6: off	JP2: 2-3 closed JP3: 1-2 closed	Flex lead 410686861 420687500	SI-8390D-02	410680550 or 410680511
LQ14X01/E 13.8", 1024x768, 18-bit 5V, 2X CCFT	JP6: 1-2 closed JP7: open JP12: open	#1: off #2: off #3: off #4: off #5: off #6: off	JP2: 2-3 closed JP3: 2-3 closed	410688102 420687451 420687511	Internal inverter	410680560 or 410680521
LQ14X03/E 13.8", 1024x768, 18-bit 5V, 2X CCFT	JP6: 1-2 closed JP7: open JP12: open	#1: off #2: off #3: off #4: off #5: off #6: off	JP2: 2-3 closed JP3: 1-2 closed	410688102 420687451 420687511	SI-8390D-02	410680550 or 410680511
LQ15X01/W 15", 1024x768, 18-bit 5V, 2X CCFT	JP6: 1-2 closed JP7: open JP12: open	#1: off #2: off #3: off #4: off #5: off #6: off	JP2: 2-3 closed JP3: 1-2 closed	410688102 420687451 420687511	SI-8390D-02	410680550 or 410680511
Toshiba						
LTM15C151A 15", 1024x768, 18-bit 5V, 2X CCFT	JP6: 1-2 closed JP7: open JP12: open	#1: on #2: off #3: off #4: off #5: off #6: off	JP2: 2-3 closed JP3: 1-2 closed	426311100	SI-8390D-02	410680550 or 410680511

Controller setup table for Special Version: 4106891-11

Panel	Panel power JP6, JP7, JP12	Panel BIOS SW1	Inverter (note 1) JP2, JP3	Panel Connection	Inverter	Control
Sharp						
LQ11DW01, LVDS 11.2", 1024x600, 18-bit 5V, 1X CCFT	JP6: 1-2 closed JP7: open JP12: open	#1: off #2: off #3: off #4: off #5: on #6: off	JP2: 1-2 closed JP3: 1-2 closed	410688632 420688611	BDA-003	410680550 or 410680511

Controller setup table for Special Version (Plasma Panel): 4106891-80

Panel	Panel power JP6, JP7, JP12	Panel BIOS SW1	Inverter (note 1) JP2, JP3	Panel Connection	Inverter	Control
Fujitsu						
FPF42C10660UD-01 42" plasma panel 852x480, 16:9	JP6: 2-3 closed JP7: 1-2 closed JP12: open	#1: on #2: off #3: off #4: off #5: off #6: off	JP2: 1-2 closed JP3: 1-2 closed	420688530 410688120 426311300	Internal inverter	410680550 or 410680511

- Remarks:
- The setting for JP2 and JP3 depends on the inverter used.
 - TBA means that the user has to read the specification of the inverter and find the control method.
 - The control information for the AC-1024 can be found on the jumper table.

SYSTEM DESIGN

A typical LCD based display system utilising this controller is likely to comprise the following:

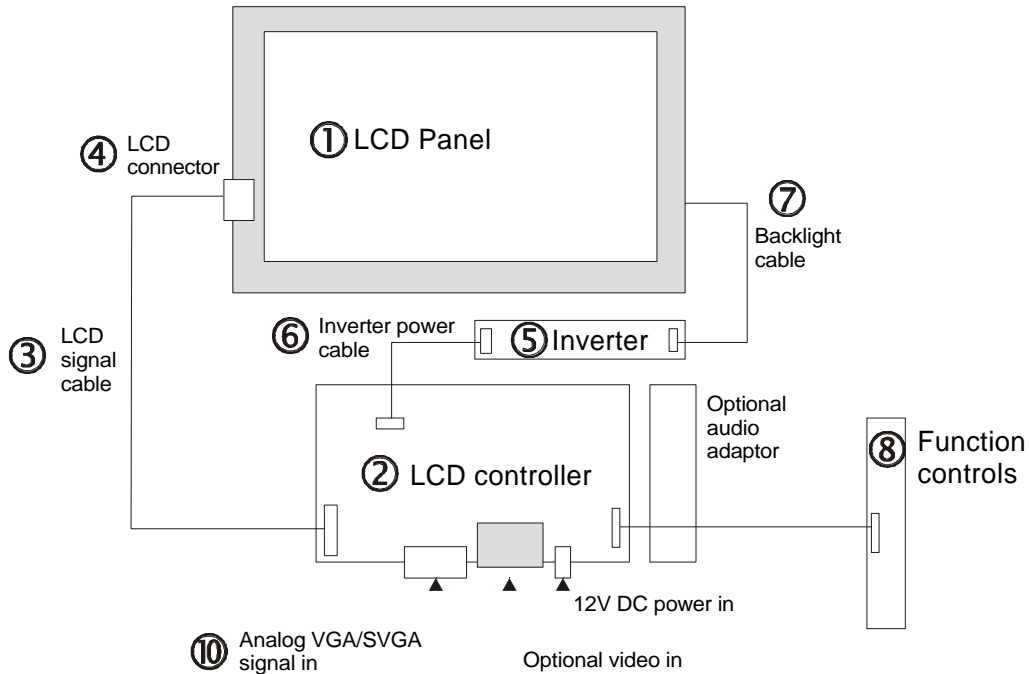

Summary:

1. LCD panel
2. LCD controller card, AC-1024
3. LCD panel signal cables
4. Connector for LCD signal cables
5. Inverter for backlight (if not built into LCD)
6. Inverter power cable
7. Inverter to backlight cable (if inverter is not part of LCD or if existing panel cable is too short)
8. Function controls
9. Function controls cable
10. External type VGA cable
 - Video connection – optional add-on board
 - Audio control – optional add-on board
 - Power supply (not shown)
 - Enclosure or Mounting (not shown).

Digital View provides a range of parts, such as listed above, to make up complete display solutions.

ASSEMBLY NOTES

This controller is designed for monitor and custom display projects using 1024 x 768 resolution TFT panels with a VGA, SVGA or XGA signal input. The following provides some guidelines for installation and preparation of a finished display solution.

- **Preparation:** Before proceeding it is important to familiarize yourself with the parts making up the system and the various connectors, mounting holes and general layout of the controller. As much as possible connectors have been labeled. Guides to connectors and mounting holes are shown in the following relevant sections.
- **1. LCD Panel:** This controller is for TFT panels with 5V or 3.3V TTL or LVDS interface. For LVDS a separate add-on board is required. Due to the variation between manufacturers panels signal timing and other panel characteristics, factory setup and confirmation should be obtained before connecting to a panel. **NOTE: Check panel power jumper settings before connection)**
- **2. Controller:** Handle the controller with care as static charge may damage electronic components.
- **3. LCD signal cables:** In order to provide a clean signal it is recommended that LCD signal cables are no longer than 33cm (13 inches). If loose wire cabling is utilised these can be made into a harness with cable ties. Care should be taken when placing the cables to avoid signal interference. Additionally it may be necessary in some systems to add ferrite cores to the cables to minimise signal noise.
- **4. LCD connector:** Different makes and models of LCD panel require different panel signal connectors and different pin assignments.

WIRING NOTE: If panels of less than 3 x 8 bit are used, eg 3 x 6 bit, then connection of panel signal high value should correspond to the controllers highest bit. For example for a 6 bit panel R5 on the panel should connect to R7 on the controller, in this case R1 & R0 on the controller will not be connected.

- **5. Inverter:** This will be required for the backlight of an LCD, some LCD panels have an inverter built in. As panels may have 1 or more backlight tubes and the power requirements for different panel backlights may vary it is important to match the inverter in order to obtain optimum performance. See Application notes for more information on connection.
- **7. Inverter to Backlight Cables:** (Not so relevant if the inverter is built into the LCD panel module). These are high tension and thus prone to power leakage. Suitable cable should be selected of minimum length, additionally care should be taken when laying out this cable.
- **8. Function Controls:** The following section discusses the controls required and the section on connectors provides the detail. The controls are minimal: On/Off, Backlight Brightness (depends on inverter), OSD (5 momentary buttons).
- **9.** The cables to the function switches should be of suitable quality and length so that impedance does not affect performance. Generally lengths up to 1 metre (3 feet) should be acceptable.

- **10. VGA Input Cable:** As this may affect regulatory emission test results and the quality of the signal to the controller a suitably shielded cable should be utilised.
- **Video input:** With the optional video input board added it is possible to accept and display PAL & NTSC signals with either S-video or composite signal. When the video add-on board is fitted OSD menu functions will be available for setting video characteristics and controlling the input source. The add-on board also provides RCA type connectors for audio input (see next note).
- **Audio control:** With the optional audio add-on board it is possible to control volume through the OSD menu. The audio board fits on the right hand edge of the main controller.
- **Power Input:** 12V DC is required, this should be a regulated supply. Although the controller provides power regulation for the LCD power this does not relate to the power supplied to the backlight inverter. If an unregulated power supply is provided to an inverter any fluctuations in power may affect operation, performance and lifetime of the inverter and or backlight tubes.
- **Power output:** Note the controller has an overall 3Amp current limit and the current available from the auxiliary power output will be dependent on the power input and other system requirements.
- **Power Safety:** Note that although only 12VDC is required as 'power-in' a backlight inverter for panel backlighting produces significantly higher voltages (the inverter does not connect to the ground plane). We strongly advise appropriate insulation for all circuitry.
- **EMI:** Shielding will be required for passing certain regulatory emissions tests. Also the choice of external Controller to PC signal cable can affect the result.
- **Ground:** The various PCB mounting holes are connected to the ground plane.
- **Servicing:** The board is not user serviceable or repairable. Warranty does not cover user error in connecting up to the controller and is invalidated by unauthorized modification or repairs.
- **Controller Mounting:** It is recommended that a clearance of at least 10mm is provided above and 5mm below the controller when mounted. Additionally consideration should be given to:
 - Electrical insulation.
 - Grounding.
 - EMI shielding.
 - Cable management. Note: It is important to keep panel signal cables apart from the inverter & backlight cables to prevent signal interference.
 - Heat & Ventilation: Heat generated from other sources, for example the backlight of a very high brightness panel may generate significant heat which could adversely affect the controller.
 - Other issues that may affect safety or performance.

- **Touch Panels:** Support for touch panels or other low power consumption accessories is available by:
 - Connector CN1 provides 5V & 12V DC which can be used to power such accessories subject to a maximum loading recommended at 500mA.
- **PC Graphics Output:** A few guidelines:
 - Signal quality is very important, if there is noise or instability in the PC graphics output this may result in visible noise on the display.
 - Refer to graphics modes table in specifications section for supported modes.
 - Non-interlaced & interlaced video input is acceptable.

IMPORTANT: Please read the Application Notes section for more information.

CONNECTION & OPERATION

CAUTION: Never connect or disconnect parts of the display system when the system is powered up as this may cause serious damage.

CONNECTION

Connection and usage is quite straightforward however care needs to be taken with:

- Ensuring parts have been correctly connected – both power & signal considerations.
- Checking that all jumpers & switches are set correctly.
- The input signal is compatible.
- Legal & safety requirements have been met.

General:

- If you are using supplied cables & accessories, ensure they are correct for the model of panel and controller.
- If you are making your own cables & connectors refer carefully to both the panel & inverter specifications and the section in this manual, “Connectors, Pinouts & Jumpers” to ensure the correct pin to pin wiring.

The steps in any order are:

- Panel signal connection.
- Panel backlight connection – Inverter & backlight tubes (see Application Notes section for more information).
- Function controls connection.
- Accessory connection, ie indicator LED, touch panel.

Then in the following specific order:

- Input signal connection (ie from the computer, ensure the computer is switched Off)
- Power supply (DC 12V, ensure correct + & - orientation).
- Power on the PC (ensure the PC settings are suitable).
- Power on the display.

PC SETTINGS

The controller has been designed to take a very wide range of input signals however to minimize the load on the PC's graphics systems we recommend choosing 60Hz vertical refresh rate – this will not cause screen flicker.

OPERATION

Once the system has been connected and switched on there are a number of functions available to adjust the display image as summarised in the following sections. The settings chosen will be saved for each mode independently.

LCD DISPLAY SYSTEM SETTINGS

NOTE: By way of explanation the following refers to a set of sample buttons that may be obtained as an option. In addition to power on/off and connection for backlight brightness the controller provides an On Screen Display of certain functions which are controlled by 5 momentary type buttons:

1. **On/Off** - power on/off: Controller, Panel & Backlight.
2. **Brightness** - if supported by inverter and correct wiring, to control backlight brightness.
3. **Menu** – turns the OSD menu On or Off (it will also auto time off)
4. **Select Down** – moves the selection indicator to the next function (down)
5. **Select Up** – moves the selection indicator to the previous function (up).
6. **+** - increase the setting
7. **-** - decrease the setting

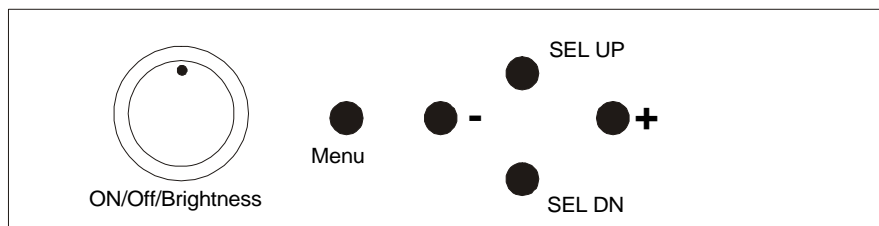

OSD functions PC input:

Volume (note 1)	Increase/decrease sound output volume if Audio board is installed
Brightness	Increase/decrease panel brightness level
Contrast	Increase/decrease panel contrast level
Tuning	Fine tune the data sampling position (adjust display quality)
Auto setup	Auto setting the display, e.g. positions, image size, tuning, etc.
FRC	Frame rate control (increase number of colors on a lower bit panel)
PC or Video	Set which input signal (PC or Video) has priority if both are connected and active.
Video input	Set which input signal (S-video or composite) has priority if both are connected and active.
RGB adjustment ▶	Adjust RGB color level of video signal
Image vertical position	Adjust the image vertical position (up & down)
Image horizontal position	Adjust the image horizontal position (left & right)
Image size – horizontal	Adjust the image horizontal size
Image expansion	Adjust vertical image size (ON = 10% expansion)
System info ▶	Shows system information by turn on the system info submenu
Exit menu	Turn off the OSD menu
Extended menu ▶	Turn on the extended menu

Items marked ▶ have sub menus.

Note 1: The Volume option will appear if dip-switch (SW1) position #4 is ON. This option will not appear if SW1 position #4 is OFF. Restart the board is required after setting of SW1 to enable the setting.

RGB Adjustment sub menu

Red	Adjust the red color level, range: 0 to 79
Green	Adjust the green color level, range: 0 to 79
Blue	Adjust the blue color level, range: 0 to 79
Reset to default	Reset the RGB color level to default
Back to main menu	Go back to main menu (press + or -)

System Info sub menu

Display type	TFT LCD 1024x768 (or other display modes, e.g. 640x480)
Model	Shows the model number of the board, e.g. AC-1024
BIOS version	Shows BIOS version
Run time	Shows the accumulated running time of the board since last reset
Back to main menu	Go back to main menu

Extended menu

Dos text or graphics	Set text mode or graphic mode in DOS mode
Direct access 1	Turn on direct access table 1
Direct access 2	Turn on direct access table 2
Signal level	Set input signal level (0.7V or 1.0V)
Exclusive or priority	Exclusive: disable "PC or Video" option; Priority: keep "PC or Video" option .
OSD vertical position	Move OSD menu vertically
OSD horizontal position	Move OSD menu horizontally
Menu time out	Set menu time-out period
Menu auto save	Yes/No
Language ▶	Select language display for OSD menu (note 2)
Back to main menu	Go back to main menu

Note 2: The AC-1024 board with part number 4106891-06 or earlier version does not support language option (this option with no function or will not display).

Direct access 1 & 2 sub menu

Volume	Define hot keys as volume increase/decrease
Brightness	Define hot keys as brightness level increase/decrease
Contrast	Define hot keys as contrast level increase/decrease
Tuning	Define hot keys as tuning adjustment
PC or Video	Define hot keys as PC or Video select
Video input	Define hot keys as video signal select (S-video or composite)
Back to previous menu	Go back to previous menu

The direct access table 1 and 2 allow the user to define the hot-keys functions. There are two sets of hot-keys can be defined. SEL UP/SEL DN keys can be defined in the direct access table 1. The +/- keys can be defined in the direct access table 2.

The hot-key function can be turned on by any one push of SEL UP/SEL DN or +/- then setting can be started.

Language sub menu

English	Select English display
Italiano	Select Italian display
Francais	Select French display
Espanol	Select Spanish display
Svenska	Select Swedish display
Deutsche	Select Dutch display
Nederlands	Select Netherlands display
Back to previous menu	Go back to previous menu

OSD functions Video input:

Volume (note 3)	Increase/decrease sound output volume if Audio board is installed
Brightness	Increase/decrease panel brightness level
Contrast	Increase/decrease panel contrast level
Tuning	Fine tune the data sampling position (adjust display quality)
Auto setup	Auto setting the display, e.g. positions, image size, tuning, etc.
FRC	Frame rate control (increase number of colors on a lower bit panel)
PC or Video	Set which input signal (PC or Video) has priority if both are connected and active.
Color	Adjust color level of video signal
Tint	Adjust tint level (functions in NTSC mode only)
Image vertical position	Adjust the image vertical position (up & down)
Image horizontal position	Adjust the image horizontal position (left & right)
Image size – horizontal	Adjust the image horizontal size
Image expansion	Adjust vertical image size (ON = 10% expansion)
System info ▶	Shows system information by turn on the system info submenu
Exit menu	Turn off the OSD menu
Extended menu ▶	Turn on the extended menu

Items marked ▶ have sub menus.

Note 3: The Volume option will appear if dip-switch (SW1) position #4 is ON. This option will not appear if SW1 position #4 is OFF. Restart the board is required after setting of SW1 to enable the setting.

The OSD settings chosen will be stored in memory. The OSD menu can be cleared from the screen by pressing the menu button otherwise it will automatically clear after a few seconds (time-out period) of non-use.

(Note: Instructions for remote control are not provided as this will depend on the handset provided)

CONNECTORS, PINOUTS & JUMPERS

The various connectors are:

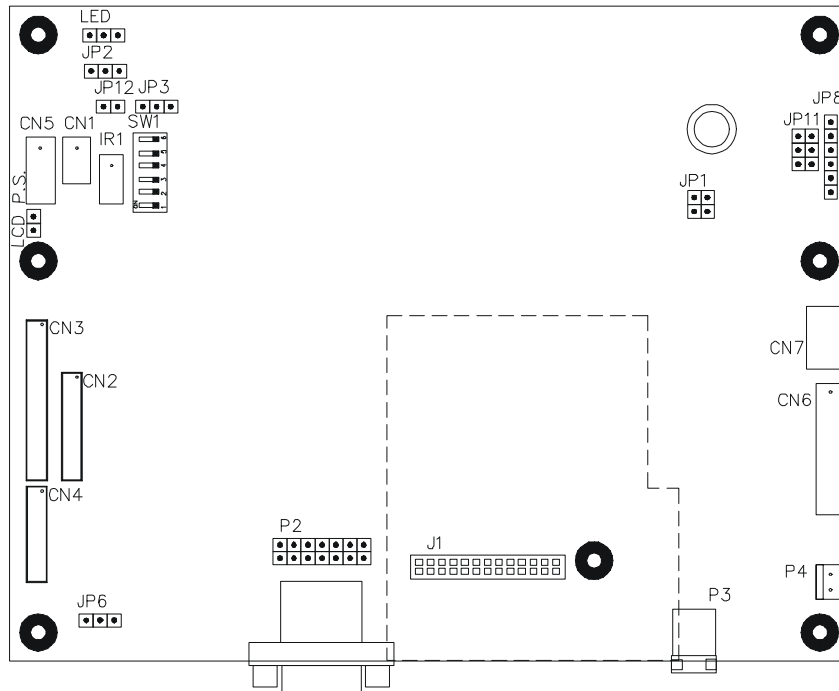

Summary: Connectors (Note 24 bit = 3 x 8 bit, 18 bit = 3 x 6 bit)

Ref	Purpose	Description
CN1	Auxiliary power	JST 4-way, B4B-XH-A
CN2	Panel signal	Hirose 28 pin, DF11-28DP-2DSA
CN3	Panel signal	Hirose 32 pin, DF11-32DP-2DSA
CN4	Panel signal – 8 bit	Hirose 20 pin, DF11-20DP-2DSA
CN5	Backlight inverter	JST 5-way, B4B-XH-A
CN6	Function controls	JST 12-way, B12B-XH-A
CN7	Audio board connector	DIL socket header 5x2 right angle
J1	Video add-on connector	DIL socket header 13x2
IR1	Infra-Red sensor connector	JST 3-way, B3B-XH-A
LED	Dual color LED connector	Header pin 3x1
P1	VGA analog input	DB-15 way high density 3 row
P2	VGA input (alternative)	Pin header, 8 x 2
P3	Main power input	DC power jack, 2.5mm contact pin diameter
P4	Power input (alternative)	DC power Molex 2 pin 0.156" pitch
P5	Power input (alternative)	DC power Molex 2 pin 0.2" pitch (not normally installed)

Summary: Jumpers setting

Ref	Purpose	Note
JP1	On board logic power enable	1-2 & 3-4 closed, factory set, do not remove
JP2	Backlight inverter on/off control – signal level	1-2 = On/Off control signal 'High' = +12V 2-3 = On/Off control signal 'High' = +5V Open = On/Off control signal 'High' = Open collector CAUTION: Incorrect setting can damage inverter.
JP3	Backlight inverter on/off control – polarity	1-2 = control signal 'high' = CCFT ON 2-3 = control signal 'low' = CCFT ON
JP4~5	Not present	
JP6	Panel data signal level	1-2 = +5V logic compatible 2-3 = +3.3V logic compatible
JP7	Panel power voltage select	1-2 = +3.3V supply Open = +5V supply
JP8	Reserved	
JP9~10	Not present	Note 3
JP11	Reserved	3-5 & 4-6 closed, factory set
JP12	+12V panel power voltage select	1-2 = enable +12V safe panel power on CN3 pin 3 Open = disable +12V panel power
SW1	Panel & function selection	See table below

Note 3: JP9 and JP10 are on the board with part number 4106891-05 or earlier. JP9 and JP10 are used to select Composite Sync or Sync on Green or Separate Sync.

Separate Sync	JP9 = 1-3 & 4-6 closed	JP10 = 3-5 & 4-6 closed
Composite Sync	JP9 = 3-5 & 2-4 closed	JP10 = 1-3 & 4-6 closed
Sync on green	JP9 = 3-5 & 4-6 closed	JP10 = 1-3 & 2-4 closed

The board with part number 4106891-06 or higher will detect the Sync method automatically and set itself to meet that Sync type (e.g. separate sync, composite sync or sync on green).

SW1: Panel and function selection

Pos. #	Function	Description
1	Clock phase change	Change this (ON/OFF) to improve image stability quality
2	Display enable selection	ON = generate DE during Sync OFF = DE during Sync
3	Special panel selection	ON = non-VESA panel mode OFF = generic panel
4	Volume selection	ON = invoke OSD volume control
5 & 6	Features selection (generic panel only)	OFF, OFF = normal image orientation ON, OFF = vertical mirror image OFF, ON = enable PanelLink™ / IT SN75LVDS86 connection ON, ON = image rotated 180°

CN1 - Auxiliary power output

PIN	SYMBOL	DESCRIPTION
1	AUX 12V	+12V DC, 300mA max
2	GND	Ground
3	GND	Ground
4	AUX 5V	+5V DC, 300mA max

CN2 - To LCD panel

PIN	SYMBOL	DESCRIPTION
1	GND	Ground
2	GND	Ground
3	ER2	Even data bit R2
4	OR2	Odd data bit R2
5	ER3	Even data bit R3
6	OR3	Odd data bit R3
7	ER4	Even data bit R4
8	OR4	Odd data bit R4
9	ER5	Even data bit R5
10	OR5	Odd data bit R5
11	EG2	Even data bit G2
12	OG2	Odd data bit G2
13	EG3	Even data bit G3
14	OG3	Odd data bit G3
15	EG4	Even data bit G4
16	OG4	Odd data bit G4
17	EG5	Even data bit G5
18	OG5	Odd data bit G5
19	EB2	Even data bit B2
20	OB2	Odd data bit B2
21	EB3	Even data bit B3
22	OB3	Odd data bit B3
23	EB4	Even data bit B4
24	OB4	Odd data bit B4
25	EB5	Even data bit B5
26	OB5	Odd data bit B5
27	GND	Ground
28	GND	Ground

CN3 - To LCD panel

PIN	SYMBOL	DESCRIPTION
1	+12v	DC +12v, reserved & not normally used
2	+12v	DC +12v, reserved & not normally used
3	NC	No connection
4	NC	No connection
5	GND	Ground
6	GND	Ground
7	ER6	Even data bit R6
8	OR6	Odd data bit R6
9	ER7	Even data bit R7 (MSB of lower colour bit panels)
10	OR7	Odd data bit R7 (MSB of lower colour bit panels)
11	EG6	Even data bit G6
12	OG6	Odd data bit G6
13	EG7	Even data bit G7 (MSB of lower colour bit panels)
14	OG7	Odd data bit G7 (MSB of lower colour bit panels)
15	EB6	Even data bit B6
16	OB6	Odd data bit B6
17	EB7	Even data bit B7 (MSB of lower colour bit panels)
18	OB7	Odd data bit B7 (MSB of lower colour bit panels)
19	GND	Ground
20	GND	Ground
21	Vcc	DC +5v, reserved & not normally used
22	Vcc	DC +5v, reserved & not normally used
23	VS	Vertical sync
24	PwrDn	Power down control signal (5v TTL)
25	HS	Horizontal sync
26	DE	Display enable
27	VLCD	Panel supply (switched)
28	VLCD	Panel supply (switched)
29	CKE	Even dot clock (shift clock)
30	CKO	Odd dot clock (shift clock)
31	GND	Ground
32	GND	Ground

CN4 - To LCD panel - for 24 bit panels only

PIN	SYMBOL	DESCRIPTION
1	GND	Ground
2	GND	Ground
3	NC	No connection
4	NC	No connection
5	ER0	Even data bit R0
6	OR0	Odd data bit R0
7	ER1	Even data bit R1
8	OR1	Odd data bit R1
9	EG0	Even data bit G0
10	OG0	Odd data bit G0
11	EG1	Even data bit G1
12	OG1	Odd data bit G1
13	EB0	Even data bit B0
14	OB0	Odd data bit B0
15	EB1	Even data bit B1
16	OB1	Odd data bit B1
17	NC	No connection
18	NC	No connection
19	GND	Ground
20	GND	Ground

CN5 - To backlight inverter

PIN	SYMBOL	DESCRIPTION
1	GND	Ground
2	VBKL	+12VDC, 1A backlight power supply
3	BLCTRL	On/Off control (enable) – see JP1, 2 & 3
4	BVR_WIP	Brightness VR – WIP
5	BVR_A	Brightness VR A

CN6 - To control switches

PIN	SYMBOL	DESCRIPTION
1	PSWIN	Power switch A
2	SW_ON	Power switch B
3	BVR_A	Backlight brightness VR pin A
4	BVR_WIP	Backlight brightness VR pin WIP
5	BVR_B	Backlight brightness VR pin B (470 ohm resistor to +5V Vcc)
6	GND	Ground
7	MENU	OSD menu button
8	-/LEFT	OSD -/Left button
9	+ /RIGHT	OSD +/Right button
10	SEL	OSD Select down button
11	SEL_UP	OSD Select up button (optional)
12	NC	No connection

The VR for brightness depends on the inverter.

The main power load for On/Off is handled by a relay on the controller.

P1 & P2 - ANALOG VGA INPUT - 15 way connector

PIN	SYMBOL	DESCRIPTION
1	PCR	Red, analog
2	PCG	Green, analog
3	PCB	Blue analog
4	ID2	Reserved for monitor ID bit 2 (grounded)
5	DGND	Digital ground
6	AGND	Analog ground red
7	AGND	Analog ground green
8	AGND	Analog ground blue
9	DDC_5V	+5V power supply for DDC (optional)
10	DGND	Digital ground
11	ID0	Reserved for monitor ID bit 0 (grounded)
12	DDC_SDA	DDC serial data
13	HS_IN	Horizontal sync or composite sync, input
14	VS_IN	Vertical sync, input
15	DDC_SCL	DDC serial clock

P3, P4 & P5 - 12VDC power supply - input

PIN	DESCRIPTION
1	+12VDC in middle pin, 2A (1.85A main auto-reset fuse protected)
2	Ground

CONTROLLER DIMENSIONS

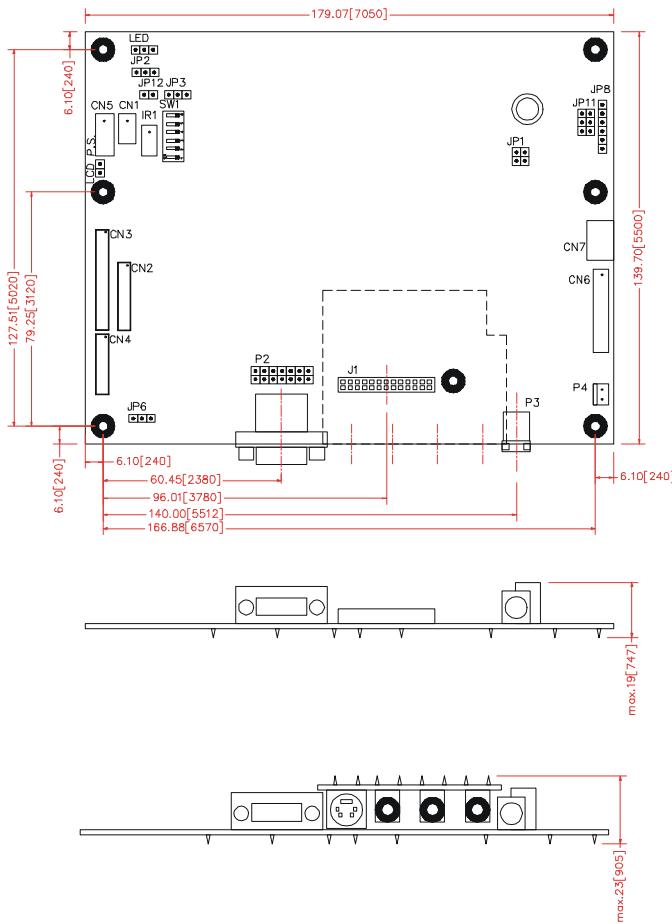

All dimension are in mm [0.001 inches]

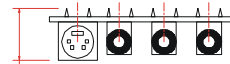
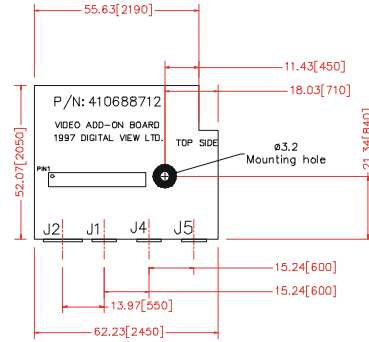

Connector:
 J1: Composite Input
 J2: S-Video Input
 J4: Audio in - Left
 J5: Audio in - Right

The maximum thickness of the controller is 23mm with or without video add-on board (measured from bottom of PCB to top of components, including any underside components & leads). We recommend clearances of:

- 5mm from bottom of PCB - if mounting on a metal plate we also recommend a layer of suitable insulation material is added to the mounting plate surface.
- 10mm above the components
- 3~5mm around the edges

Any of the holes shown above can be used for mounting the PCB, they are 3.2mm in diameter.

CAUTION: Ensure adequate insulation is provided for all areas of the PCB with special attention to high voltage parts such as the inverter.

APPLICATION NOTES

USING THE CONTROLLER WITHOUT BUTTONS ATTACHED

This is very straightforward:

- Firstly setup the controller/display system with the buttons. With controls attached and display system active make any settings for colour, tint and image position as required then switch everything off.
- Remove the control switches, the 12-way (CN6) cable.
- Use a jumper or similar to connect pins 1 & 2 on CN6, this will fix the board On.
- Refer to inverter specifications for details as to fixing brightness to a desired level, this may require a resistor, an open circuit or closed circuit depending on inverter.

Summary: On CN6 the only pins that are used are for On/Off and Brightness (if controller mounted inverter is used). On CN6 the pins are for momentary type buttons so it doesn't matter that no buttons are attached.

INVERTER CONNECTION

There are potentially 3 issues to consider with inverter connection:

- Power
- Enable
- Brightness

Please read the following sections for a guide to these issues.

Inverter Power: As per the table for CN5 pin 1 is ground and pin 2 provides 12V DC. This should be matched with the inverter specification: see table.

CN5

PIN	DESCRIPTION
1	Ground
2	+12VDC

Enable: This is a pin provided on some inverters for On/Off function and is used by this panel controller for VESA DPMS compliance. If the inverter does not have an enable pin or the enable pin is not used then DPMS will not be operational. Pin 3 should be matched to the inverters specification for the 'enable' or 'disable' pin.

CN5

PIN	DESCRIPTION
3	Enable

Further, jumpers 2 & 3 should be set to match the inverters specification for the enable pin power and High or Low setting: see table.

Ref	Purpose	Note
JP2	Inverter enable voltage	1-2 H = 12V, 2-3 H = 5V (Vcc), OPEN H = open collector
JP3	Inverter control	1-2 H = On, 2-3 L = On

Brightness: There are various methods for brightness control and it is important to consider the specifications for the inverter to be used. Generally the situation is:

- Brightness can be controlled by using a resistor or VR (Variable Resistor).
- Brightness controlled by adding a circuit such as PWM (Pulse Width Modulation).
- No adjustment of brightness is possible.

CN5 pins 4 & 5 are available for connecting to an inverter or circuit where VR control is supported.

CN5

PIN	DESCRIPTION
4	VR WIP
5	VR A

This can then be matched with function controls connected to CN6 pins 4 & 3 or 5: see table.

CN6

PIN	DESCRIPTION
3	VR A
4	VR WIP
5	VR B

TROUBLESHOOTING

General

A general guide to troubleshooting a flat panel display system it is worth considering the system as separate elements, such as:

- Controller (jumpers, PC settings)
- Panel (controller, cabling, connection, panel, PC settings)
- Backlight (inverter, cabling, backlight tubes)
- Cabling
- Computer system (display settings, operating system)

Through step by step cross checking with instruction manuals and a process of elimination to isolate the problem it is usually possible to clearly identify the problem area.

No image:

- If the panel backlight is not working it may still be possible to just see some image on the display.
- A lack of image is most likely to be caused by incorrect connection, lack of power, failure to provide a signal or incorrect graphic card settings.

Image position:

- If it is impossible to position the image correctly, ie the image adjustment controls will not move the image far enough, then test using another graphics card. This situation can occur with a custom graphics card that is not close to standard timings or if something is in the graphics line that may be affecting the signal such as a signal splitter (please note that normally a signal splitter will not have any adverse effect).

Image appearance:

- A faulty panel can have blank lines, failed sections, flickering or flashing display
- Incorrect graphics card refresh rate, resolution or interlaced mode will probably cause the image to be the wrong size, to scroll, flicker badly or possibly even no image.
- Incorrect jumper settings on the controller may cause everything from total failure to incorrect image. CAUTION: Do not set the panel power input incorrectly.
- Sparkling on the display: faulty panel signal cable.

Backlight:

Items to check include: Power input, Controls, Inverter and Tubes generally in this order. If half the screen is dimmer than the other half:

- Check cabling for the inverter.
- For a specific backlight tube check the AC pins orientation (CAUTION: Never reverse any DC power pins).

Also:

- If adjusting brightness control has no effect the chances are that the VR rating or method of adjusting brightness is not compatible or correctly connected to the inverter.
- If system does not power down when there is a loss of signal

Continued failure:

- If unit after unit keeps failing consider and investigate whether you are short circuiting the equipment or doing something else seriously wrong.

Generally after common sense issues have been resolved we recommend step by step substitution of known working parts to isolate the problem.

SPECIFICATIONS

Panel compatibility	Compatible with 1024 x 768 resolution TFT LCD's from manufacturers such as Sharp, Toshiba, Hosiden, Hitachi, LG, Samsung, Fujitsu though a specified BIOS and some factory adjustment may be required for individual panel timings.
No. of colours	Up to 3 x 8 bit providing 16.7 million colours.
Vertical refresh rate	VGA, SVGA, XGA to VESA standards up to 120Hz
Dot clock (pixel clock) maximum	160MHz
Graphics formats	Standard VGA, SVGA, XGA
Graphics auto mode detect	VGA, SVGA, XGA
Standard input at source	VGA analog (15 pin) standard, composite sync & sync on green.
Video inputs (optional video board)	<ul style="list-style-type: none"> • Composite video: 1.0v (p-p) 75Ω, negative sync • S-Video: Y 1.0v (p-p) 75Ω, negative sync, C 0.286v (p-p) 75Ω
Controls available	<ul style="list-style-type: none"> • On/Off • Brightness – inverter • OSD Menu • OSD Select up • OSD Select down • Setting + • Setting -
Control interface	<ul style="list-style-type: none"> • Buttons • Infra red • RS-232
Settings memory	Settings are stored in non volatile memory
Run time monitor	Updates at 30 minute intervals
PC Connectivity	VGA / SVGA / XGA analog
Controller dimensions	179mm x 140mm (7.05" x 5.5")
Power consumption	10w approx. (not including panel power consumption)
Power load maximum	The controller has an overall 3Amp current limit.
Voltage output for LCD	+3.3V DC, +5V DC, +12V DC
Input voltage	12VDC
Power protection	Fuse fitted
DC Power handling	An on board relay handles the power load for On/Off and power protection to the LCD.
Storage temperature limits	-40°C to +70°C
Operating temperature limits	0°C to +65°C

NOTES

Please note the following:

- For specific panel setup a sample of an LCD may be required (this will be returned) and a copy of the full technical specifications for the panel from the manufacturer.
- Relay and custom development services are available.

WARRANTY

The products are warranted against defects in workmanship and material for a period of one (1) year from the date of purchase provided no modifications are made to it and it is operated under normal conditions and in compliance with the instruction manual.

The warranty does not apply to:

- Product that has been installed incorrectly, this specifically includes but is not limited to cases where electrical short circuit is caused.
- Product that has been altered or repaired except by the manufacturer (or with the manufacturer's consent).
- Product that has subjected to misuse, accidents, abuse, negligence or unusual stress whether physical or electrical.
- Ordinary wear and tear.

Except for the above express warranties, the manufacturer disclaims all warranties on products furnished hereunder, including all implied warranties of merchantability and fitness for a particular application or purpose. The stated express warranties are in lieu of all obligations or liabilities on the part of the manufacturer for damages, including but not limited to special, indirect consequential damages arising out of or in connection with the use of or performance of the products.

CAUTION

Whilst care has been taken to provide as much detail as possible for use of this product it cannot be relied upon as an exhaustive source of information. This product is for use by suitably qualified persons who understand the nature of the work they are doing and are able to take suitable precautions and design and produce a product that is safe and meets regulatory requirements.

LIMITATION OF LIABILITY

The manufacturer's liability for damages to customer or others resulting from the use of any product supplied hereunder shall in no event exceed the purchase price of said product.

TRADEMARKS

The following are trademarks of Digital View Ltd:

- Digital View
- AC-1024

CONTACT DETAILS

Digital View has offices in Asia, Europe and USA also an internet site:

ASIA

Digital View Ltd
2201 Nanyang Plaza
57 Hung To Road
Kwun Tong, Kowloon
Hong Kong

Tel: (852) 2861 3615

Fax: (852) 2520 2987

Sales: sales@digitalview.com.hk

Technical Support: technical@digitalview.com.hk

EUROPE

Digital View Ltd
Millenium Studios
5 Elstree Way
Borehamwood,
Hertfordshire, WD6 1SF
England

Tel: (44) (0)181-236 1112

Fax: (44) (0)181-236 1116

Sales: sales@digitalview.co.uk

Support: support@digitalview.co.uk

USA

Digital View Inc.
18440 Technology Drive, Building 130
Morgan Hill,
California, 95037
USA

Tel: (1) 408-782 7773

Fax: (1) 408-782 7883

Sales: sales@digitalview.com

Support: support@digitalview.com

WEBSITE

www.digitalview.com